



# PIPE HANGERS & SUPPORTS

**FIGURE H 531 STANDARD ADJUSTABLE CLEVIS HANGER**



- **MATERIAL** : CARBON STEEL
- **FINISH** : ELECTRO - GALVANIZED. HOT DIP - GALVANIZED
- **CONFORMS WITH** : SPECIFICATION WW-H-171E (TYPE 1) MSS SP-69

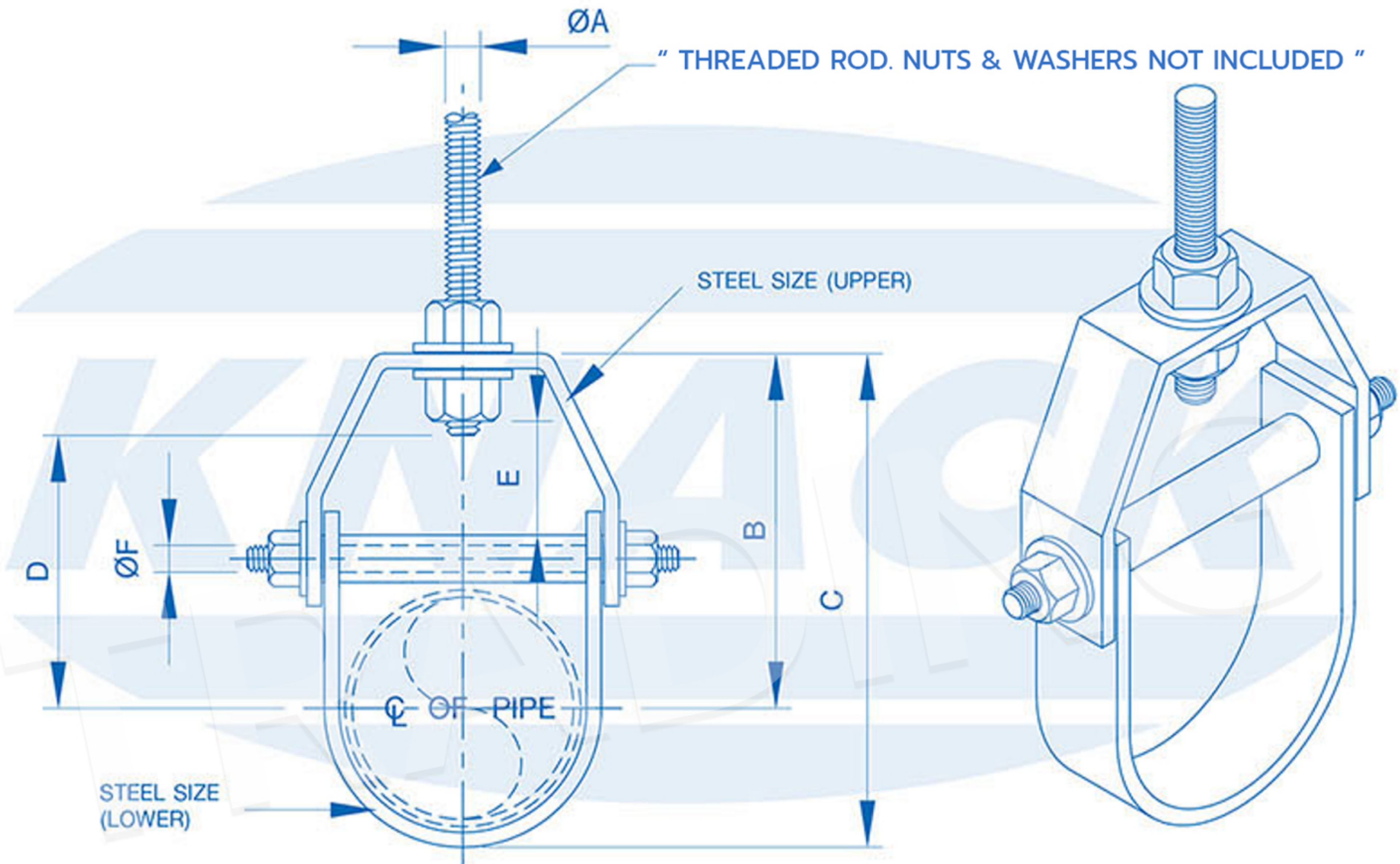

NOMINAL INCH	PIPE SIZE MM.	STEEL SIZE		ROD SIZE		B	C	D	Adjustment E	F
		UPPER	LOWER	A						
				INCH	MM.					
2	50	3 x 25	3 x 25	3/8	9.5	105	140	75	42	6
2 1/2	65	5 x 32	5 x 32	1/2	12.7	124	160	97	44	9
3	80	5 x 32	5 x 32	1/2	12.7	128	175	98	44	9
4	100	6 x 32	5 x 32	5/8	15.9	147	210	114	50	9
5	125	6 x 32	5 x 32	5/8	15.9	165	240	130	44	12
6	150	6 x 38	5 x 38	3/4	19	185	275	142	47	12
8	200	6 x 50	5 x 50	7/8	22.2	247	355	178	54	15
10	250	9 x 50	6 x 50	7/8	22.2	290	430	212	57	19
12	300	9 x 50	6 x 50	7/8	22.2	325	495	258	76	19
14	350	12 x 50	6 x 50	1	25.4	390	575	275	75	22
16	400	12 x 63	6 x 63	1	25.4	425	650	316	76	25
18	450	12 x 63	6 x 63	1 1/8	28.6	454	690	354	95	29
20	500	15 x 75	9 x 75	1 1/4	31.7	465	720	367	101	32
24	600	15 x 75	9 x 75	1 1/4	31.7	498	803	444	108	32
26	650	15 x 75	9 x 75	1 1/4	31.7	549	890	495	116	32
30	750	15 x 75	9 x 75	1 1/4	31.7	613	994	556	127	32

